

FORGED STEEL VALVE SERIES 锻钢阀系列

SAFE AND RELIABLE YOUZHONG MADE IT WITH HEART
安全又可靠 优众用心造



VALVE ORDER NUMBER 阀门订货号

当您询问或订购我们的阀门时不必详细了解我们的阀门订货编号系统。只要您能提供了您能所选阀门的充分描述，我们的销售部门就可以将其编译成相应的阀门订货号。所选阀门的充分描述应该是从阀门类型开始的，接着就是阀门口径、压力等级、两端连接形式、密封面材或根据API 602所规定的内件号等。

下面是我们给出的一个例子，目的是想用图示的方法来说明一个典型的阀门订货号，但如果需要详细地说明，请向我们咨询。

When you ask or order our valves do not have to learn more about our valves order numbering system. As long as you can provide your full description of the selected valve, our sales department can be made up Translated into the corresponding valve order number. The selected valve fully described should be started from the valve type, then there is the valve diameter, pressure level, form of connection on both ends, sealing surface material or according to API 602 Regulation of internal parts and so on.

Below is we give an example, the purpose is to want to use the method of graphic to illustrate a typical valve order number, but if you need to elaborate, please consult us.

F 通径形式 Port type		P 阀体与阀盖链接形式 Body and bonnet connection		3 末端链接形式 End connection		Y 设计结构特点 Design feaature		2" 口径 Size	15 压力等级 Pressure rating		L 阀门类型 Type of valve		Y 密封 (阀瓣/ 阀座) Seal disc/seat		V 阀门材质 Body materials	
缩径 Reduced	默认 Default	体、盖 螺栓链接 Bolt and bonnet screwed	默认 Default	凸面法兰 Convex llage	1	"Y"型阀门 "Y" type valves	Y	3/8"	Class150	1	闸阀Gzte valves	G	13Cr/13Cr	H	A105	C
全通径 Full bore	F			环连接 Ring connection surface	2	低温阀门 Cryogenic valves	D	3/4"	Class300	3	升降式上回阀 Lift check valves	C	STL/STL	Y	A350LF2	E
		体、盖 焊接链接 Bolt and bonnet welded	W	对接焊 Butt welded	3	波纹管阀门 Bellows valves	W	1/2"	Class600	6	球形止回阀 Ball check valves	B	13Cr/STL	HY	A182F11	A
				承焊 Socket welding	4	阀体延长端阀门 Body extended valves	E	1"	Class800	8	截止阀 Globe valves	L	304/304	S	A182F22	V
		压力自紧式 Pressure seal	P	螺纹连接 Screw	5				1/4"	Class900	9	旋启式止回阀 Swing check valves	S	304/PTFE	SF	A182F304
						A182F316										R
						保温阀 Jacket valves	B	1/2"	Class1500	15	球阀 Ball valves	Q	Monel/Monel	M	A182F304L	S
								2"	Class2500	25	线性调节阀 Linear regulating valves	T	尼龙Inconel	I	A182F316L	L
											过滤器 strainer	R	Nylon	N	A182F91	Z
												PTFE	F		A182F51	B
												Hastelloy	HC		Monel	M
															Hastelloy	H
															20合金Alloy	N

典型零件材料表 Main part materials list

零件名称 Part name	A105/F6a	A105/F6aHFS	LF2/304	F11/F6aHT	F304(L)304(L)	F316(L)316(L)	F51/F51
阀体Body	A105	A105+HF	Lf2	F11+HF	F304	F316	F51
阀瓣Disc	F6a	F6a	F304	F6aHF	F304(L)	F216(L)	F51
阀杆Stem	410	410	304	410	304(L)	316(L)	F51
垫片Gasket	304+柔性石墨 Flexible graphite	304+柔性石墨 Flexible graphite	304+柔性石墨 Flexible graphite	304+柔性石墨 Flexible graphite	304+柔性石墨 Flexible graphite	304+柔性石墨 Flexible graphite	304+柔性石墨 Flexible graphite
阀盖Bonnet	A105	A105	LF2	F11	F304(L)	F316(L)	F51
螺栓Bolt	B7	B7	L7	B16	B8(M)	B8(M)	B8M
销轴Pin	410	410	410	410	304	304	304
填料压套Gland	410	410	304	410	304	316	F51
活节螺栓Gland Eyebolt	B7	B7	L7	B16	B8(M)	B8(M)	B8M
填料压盖Gland Flange	A105	A105	LF2	F304	F304(L)	F316(L)	F304
六角螺母Hex Nut	2H	2H	7	7	8(M)	8(M)	8M
阀杆螺母Stem Nut	410	410	410	410	410	410	410
缩紧螺母Locking Nut	35	35	35	35	35	35	35
铭牌Nameplate	AL	AL	AL	AL	AL	AL	AL
手轮 Handwheel	A197	A197	A197	A197	A197	A197	A197
填料 Packing	石墨 Graphite	石墨 Graphite	石墨 Graphite	石墨 Graphite	石墨 Graphite	石墨 Graphite	石墨 Graphite

INTERNAL THREAD AND SOCKET WELDED GATE VALVE

内螺纹与承插焊闸阀

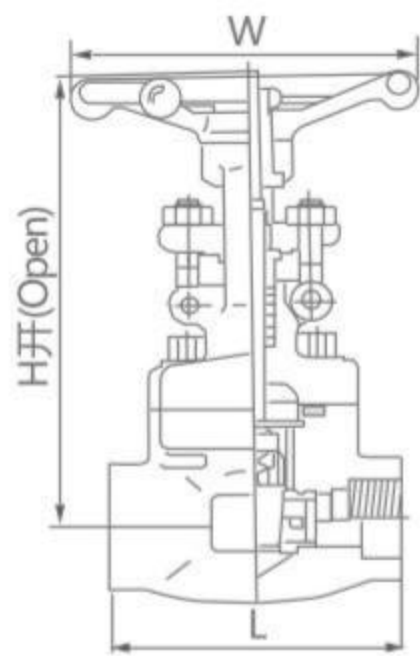

CL800

规格(NPS) Specification	R.P	-	1/2	3/4	1	1 1/4	1 1/2	2	2 1/2	3
	F.P	1/4	3/8	1/2	3/4	1	1 1/4	1 1/2	2	2 1/2
结构长度(mm)Face to face	L	79	79	92	111	120	120	140	178	180
手轮直径(mm) Handwheel diameter	W	100	100	100	125	160	160	180	200	220
中心高度(开)(mm)Height	H	161	161	163	196	223	251	290	333	370
流道孔径(mm)Flow port dimension	d	8	10.5	13.5	18	24	29	36.5	45	51
重量(Kg)Weight		2.22	2.3	4.24	4.24	5.7	7.05	10.9	16.3	24

焊接连接阀盖, 缩径和全径, 明杆支架 (OS&Y), 末端连接为螺纹或承插焊或对焊, 设计按APL602
Bolted bonnet, full port reducing port outside screw and yoke(OS&Y)
Threaded, butt-welded or socket welded ends; desing to APL602

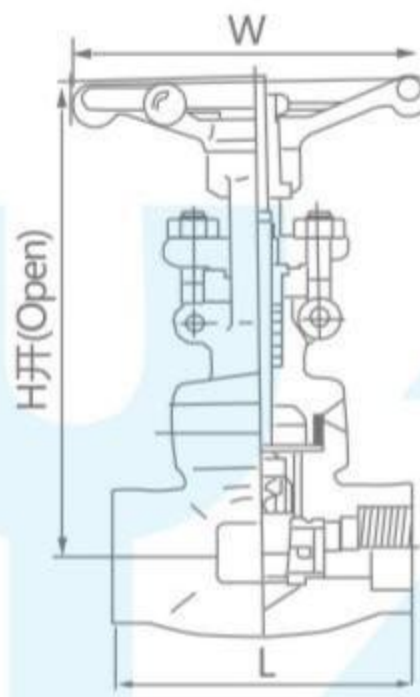

CL800

规格(NPS) Specification	R.P	-	1/2	3/4	1	1 1/4	1 1/2	2	2 1/2	3
	F.P	1/4	3/8	1/2	3/4	1	1 1/4	1 1/2	2	2 1/2
结构长度(mm)Face to face	L	79	79	92	111	120	120	140	178	180
手轮直径(mm) Handwheel diameter	W	100	100	100	125	160	160	180	200	220
中心高度(开)(mm)Height	H	161	161	163	196	223	251	290	333	370
流道孔径(mm)Flow port dimension	d	8	10.5	13.5	18	24	29	36.5	45	51
重量(Kg)Weight		1.9	1.9	2.1	3.2	5.2	6.9	10.4	15.8	22

焊接连接阀盖, 缩径和全径, 明杆支架 (OS&Y), 末端连接为螺纹或承插焊或对焊, 设计按APL602
Bolted bonnet, full port reducing port outside screw and yoke(OS&Y)
Threaded, butt-welded or socket welded ends; desing to APL602

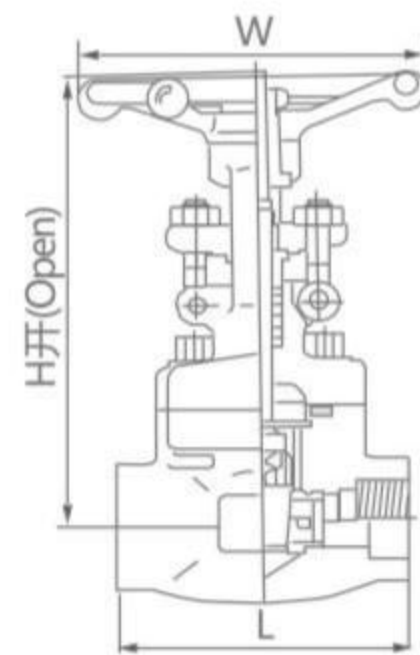

CL900-CL1500

规格(NPS) Specification	R.P	-	1/2	3/4	1	1 1/4	1 1/2	2	2 1/2	3
	F.P	1/4	3/8	1/2	3/4	1	1 1/4	1 1/2	2	2 1/2
结构长度(mm)Face to face	L	92	111	111	120	120	140	178	180	-
手轮直径(mm) Handwheel diameter	W	100	125	125	160	160	180	200	220	-
中心高度(开)(mm)Height	H	191	191	192	219	243	296	316	370	-
流道孔径(mm)Flow port dimension	d	8	10.5	13.5	18	24	29	36.5	45	-
重量(Kg)Weight		2.4	4.3	4.4	6	7.2	11.4	16	23	-

焊接连接阀盖, 缩径和全径, 明杆支架 (OS&Y), 末端连接为螺纹或承插焊或对焊, 设计按APL602
Bolted bonnet, full port reducing port outside screw and yoke(OS&Y)
Threaded, butt-welded or socket welded ends; desing to APL602

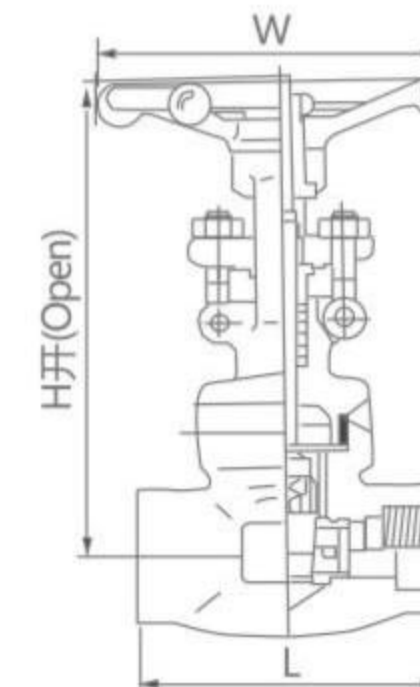

CL900-CL1500

规格(NPS) Specification	R.P	-	1/2	3/4	1	1 1/4	1 1/2	2	2 1/2	3
	F.P	1/4	3/8	1/2	3/4	1	1 1/4	1 1/2	2	2 1/2
结构长度(mm)Face to face	L	92	111	111	120	120	140	178	180	-
手轮直径(mm) Handwheel diameter	W	100	125	125	160	160	180	200	220	-
中心高度(开)(mm)Height	H	191	191	192	219	243	296	316	370	-
流道孔径(mm)Flow port dimension	d	8	10.5	13.5	18	24	29	36.5	45	-
重量(Kg)Weight		2.3	4	4	4.8	7.1	11	16	22.8	-

焊接连接阀盖, 缩径和全径, 明杆支架 (OS&Y), 末端连接为螺纹或承插焊或对焊, 设计按APL602
Bolted bonnet, full port reducing port outside screw and yoke(OS&Y)
Threaded, butt-welded or socket welded ends; desing to APL602

INTERNAL THREAD AND SOCKET WELDED GATE VALVE

内螺纹与承插焊闸阀

CL2500

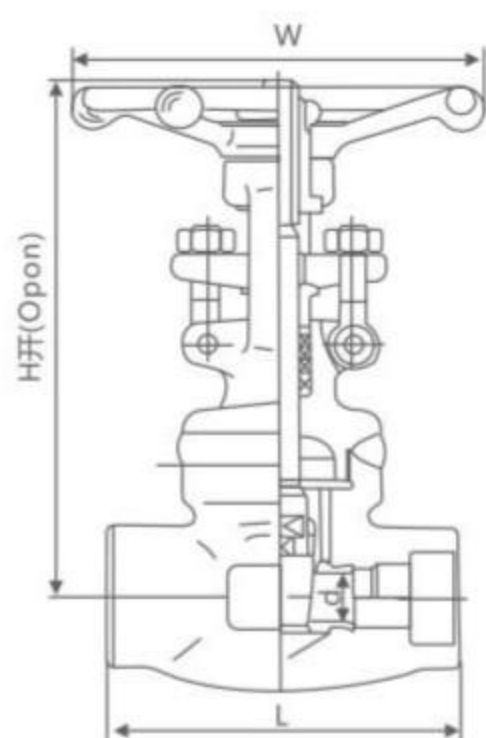

规格(NPS) Specification		1/4	3/8	1/2	3/4	1	1 1/4	2
结构长度(mm)Face to face	L		111	120	120	120	140	
手轮直径(mm)Handwheel diameter	W		125	160	160	180	220	
中心高度(开)(mm)Height	H		215	218	220	238	281	
流道孔径(mm)Flow port dimension	d		14	14	14	19	25	
重量(Kg)Weight			7	8.5	8.7	11.7	17	

焊接连接阀盖, 全径, 明杆支架 (OS&Y), 末端连接为承插连接, 设计按ASME B16.34

Welded bonnet, full port outside screw and yoke(OS&Y)

Socket welded ends, design conform to ASME B16.34

CL1500-CL2500

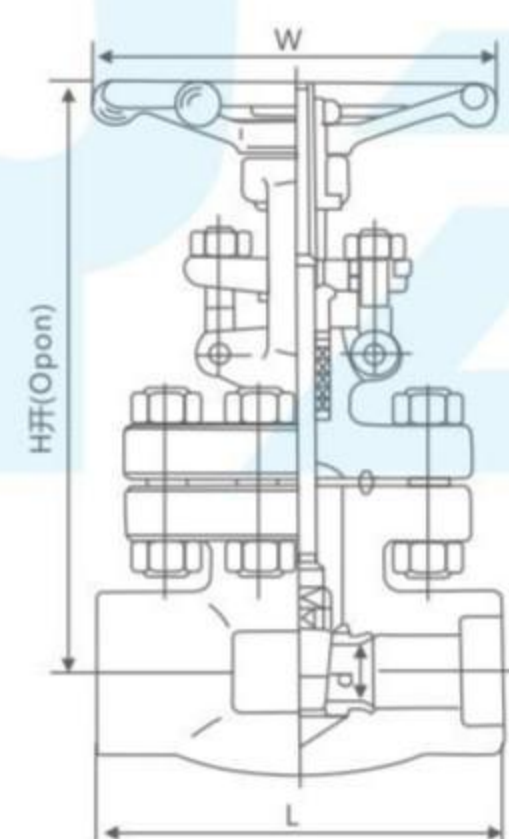

规格(NPS) Specification	F.P		1/2	3/4	1	1 1/4	1/2	2	2 1/2
结构长度(mm)Face to face	L	CL1500	110	150	150		210	235	
		CL2500	150	150	210		235	235	
手轮直径(mm)Handwheel diameter	W	CL1500	110	130	130		180	250	
		CL2500	130	130	250		300	300	
中心高度(开)(mm)Height	H	CL1500	277	300	390		400	435	
		CL2500	293	300	390		435	435	
流道孔径(mm)Flow port dimension	d	CL1500	14	17	22		35	37	
		CL2500	14	14	14		25	30	
重量(Kg)Weight		CL1500	5.1	11	12.1		22	37	
		CL2500	11	11.3	22.4		38	38	

焊接连接阀盖, 全径, 明杆支架 (OS&Y), 末端连接为承插连接, 设计按ASME B16.34

Welded bonnet, full port outside screw and yoke(OS&Y)

Socket welded ends, design conform to ASME B16.34

CL1500-CL2500

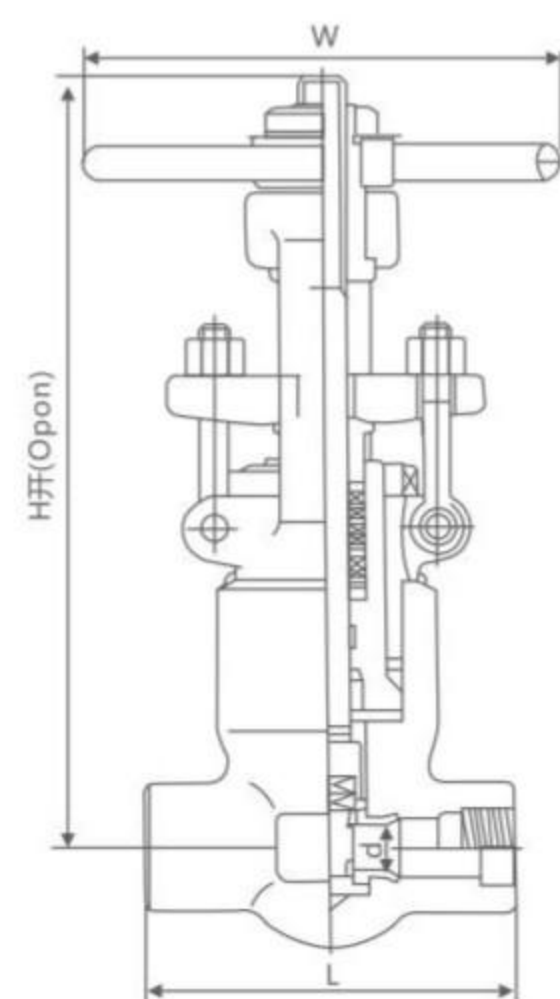

规格(NPS) Specification	F.P		1/2	3/4	1	1 1/4	1/2	2	2 1/2
结构长度(mm)Face to face	L	CL900-1500	140	140	140	140	178	178	216
		CL2500	186	186	186	186	232	232	279
手轮直径(mm)Handwheel diameter	W	CL900-1500	200	200	200	200	280	280	300
		CL2500	200	200	200	200	280	280	300
中心高度(开)(mm)Height	H	CL900-1500	318	318	318	322	467	468	540
		CL2500	325	325	325	327	467	468	540
流道孔径(mm)Flow port dimension	d	CL900-1500	14	14	14	19	25	30	36.5
		CL2500	14	14	14	19	25	30	36.5
重量(Kg)Weight		CL900-1500	11.5	11.5	10.8	10.5	19.6	21	55.4
		CL2500	10.8	11.6	12.3	12.3	26	28.4	60

焊接连接阀盖, 全径, 明杆支架 (OS&Y), 末端连接为承插连接, 设计按ASME B16.34

Welded bonnet, full port outside screw and yoke(OS&Y)

Socket welded ends, design conform to ASME B16.34

FORGED STEEL FLANGE GATE VALVES

锻钢法兰闸阀

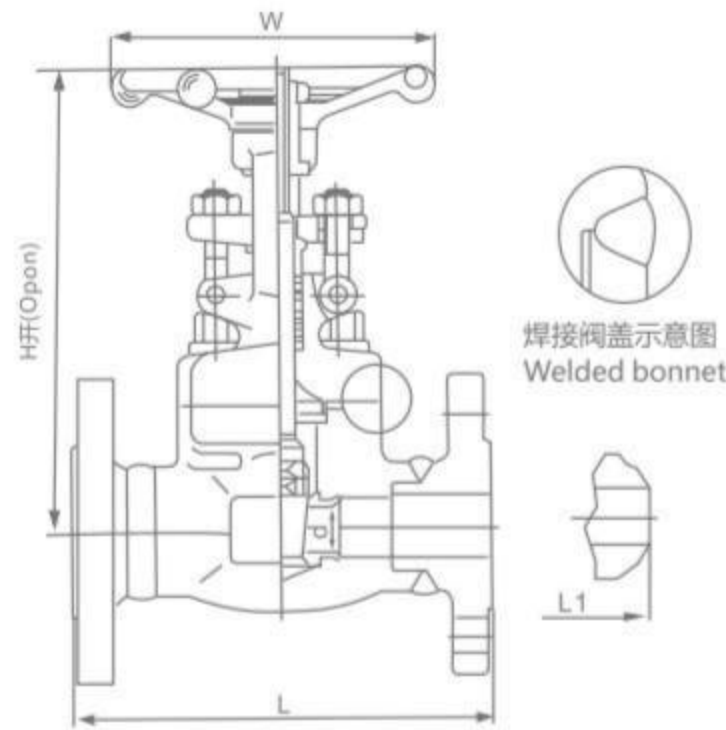

CL150-300-600

规格(NPS) Specification			1/4	3/8	1/2	3/4	1	1 1/4	1 1/2	2	2 1/2
结构长度(mm) Face to face	CL150	L(RF) L1(BW)	-	-	108	117	127	140	165	178	190
	CL300		-	-	140	152	165	178	190	216	241
	CL600		-	-	165	190	216	229	241	292	330
手轮直径(mm) Handwheel diameter	W		-	-	100	100	125	160	160	180	200
中心高度(开) (mm)Height	CL150/CL300	H	-	-	176	184	217	226	250	290	357
	CL600		-	-	161	163	196	226	250	290	357
流道孔径(mm)Flow port dimension	d		-	-	10	13.5	18	24	29	36.5	45
重量(Kg) Weight	CL150	RF	-	-	3.4	3.98	6.12	7.2	10.4	15.5	24.5
		BW	-	-	2.8	3.3	5.4	6.5	8.2	12.5	20
	CL300	RF	-	-	3.77	4.89	7.23	9.6	12.64	18	26.2
		BW	-	-	3.5	4.4	6.8	8.1	9.2	15.4	22
	CL600	RF	-	-	4.2	5.8	8.8	12.1	15.6	19.5	32
		BW	-	-	4.5	5.1	8.2	10.5	12.4	20.1	28

螺栓连接阀盖, 缩径和全径, 明杆支架 (OS&Y), 末端连接为法兰或对焊连接, 设计按API 602;BS5352
Bolted bonnet, full port reducing port outside screw and yoke(OS&Y)
Flange-welded or but-welded ends; design to API602;BS5352

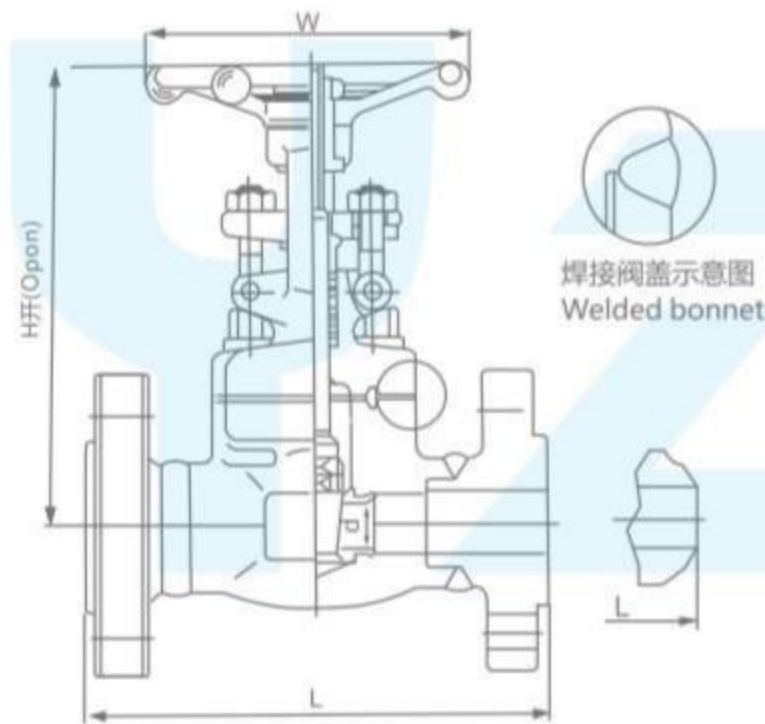

CL900-CL1500

规格(NPS) Specification		F. P	1/4	3/8	1/2	3/4	1	1 1/4	1 1/2	2
结构长度(mm) Face to face	L(RF)L1(BW)		-	-	216	229	254	279	305	368
	L(RTJ)		-	-	216	229	254	279	305	371
手轮直径(mm) Handwheel diameter	W		-	-	125	125	160	180	200	220
中心高度(开)(mm)Height	H		-	-	191	192	219	257	296	316
流道孔径(mm)Flow port dimension	d		-	-	13.5	18	24	29	36.5	45
重量(Kg) Weight			-	-	7.2	11.5	15.6	16.2	22.6	28.2

螺栓连接阀盖, 缩径和全径, 明杆支架 (OS&Y), 末端连接为法兰或对焊连接, 设计按API 602;BS5352
Bolted bonnet, full port reducing port outside screw and yoke(OS&Y)
Flange-welded or but-welded ends; design to API602;BS5352

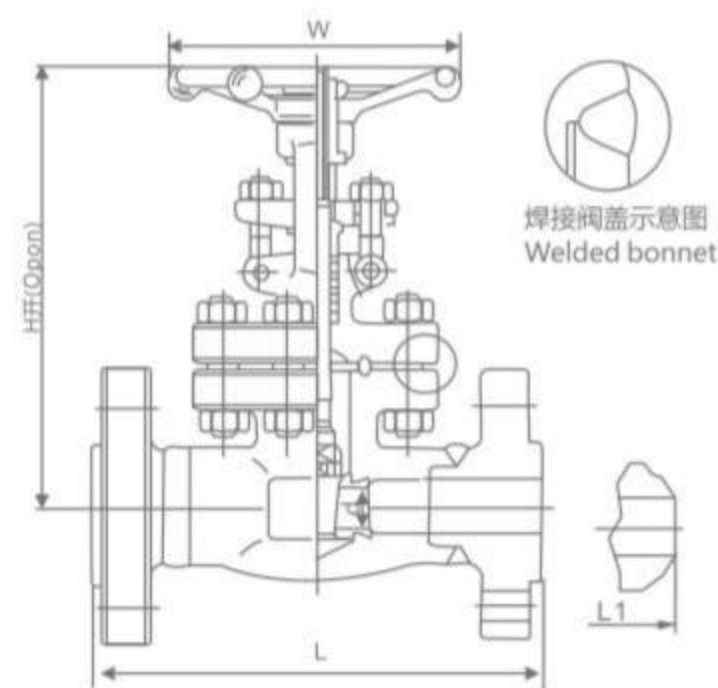

CL2500

规格(NPS) Specification		F. P	1/4	3/8	1/2	3/4	1	1 1/4	1 1/2	2
结构长度(mm) Face to face	L(RF)L1(BW)		-	-	264	273	305	-	384	451
	L(RTJ)		-	-	264	273	308	-	387	454
手轮直径(mm) Handwheel diameter	W		-	-	125	160	160	-	200	240
中心高度(开)(mm)Height	H		-	-	207	240	258	-	355	370
流道孔径(mm)Flow port dimension	d		-	-	13.5	13.5	19	-	20	36.5
重量(Kg) Weight			-	-	19.5	21.5	42	-	65	95

螺栓连接阀盖, 缩径和全径, 明杆支架 (OS&Y), 末端连接为法兰或对焊连接, 设计按API 602;BS5352
Bolted bonnet, full port reducing port outside screw and yoke(OS&Y)
Flange-welded or but-welded ends; design to API602;BS5352

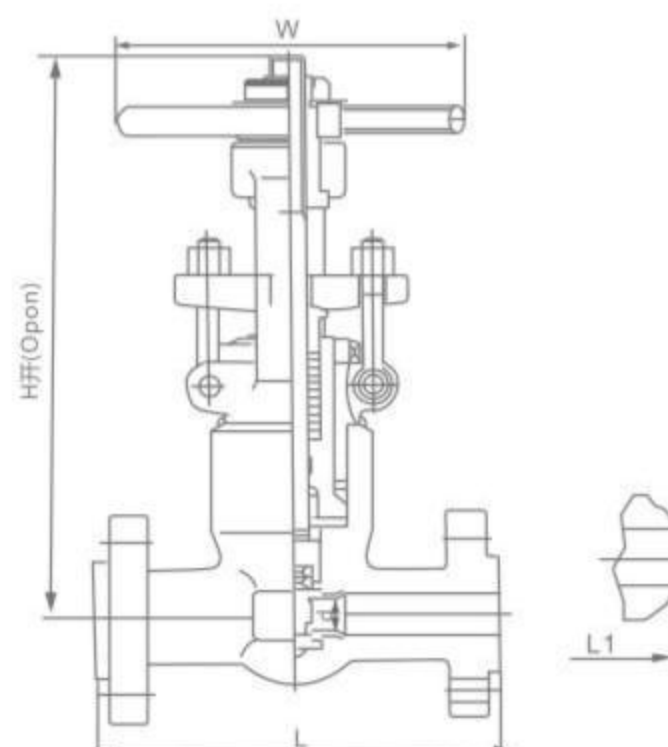

CL2500

规格(NPS) Specification		F. P	1/4	3/8	1/2	3/4	1	1 1/4	1 1/2	2
结构长度(mm) Face to face	L(RF)L1(BW)		-	-	264	273	308	-	384	451
	L(RTJ)		-	-	264	273	308	-	387	454
手轮直径(mm) Handwheel diameter	W		-	-	200	200	200	-	280	300
中心高度(开)(mm)Height	H		-	-	325	325	327	-	478	540
流道孔径(mm)Flow port dimension	d		-	-	13.5	13.5	19	-	30	36.5
重量(Kg) Weight			-	-	14.6	16.8	17.6	-	25	31.9

螺栓连接阀盖, 缩径和全径, 明杆支架 (OS&Y), 末端连接为法兰或对焊连接, 设计按API 602;BS5352
Bolted bonnet, full port reducing port outside screw and yoke(OS&Y)
Flange-welded or but-welded ends; design to API602;BS5352

INTERNAL THREAD AND SOCKET WELD STOP VALVE

内螺纹与承插焊截止阀

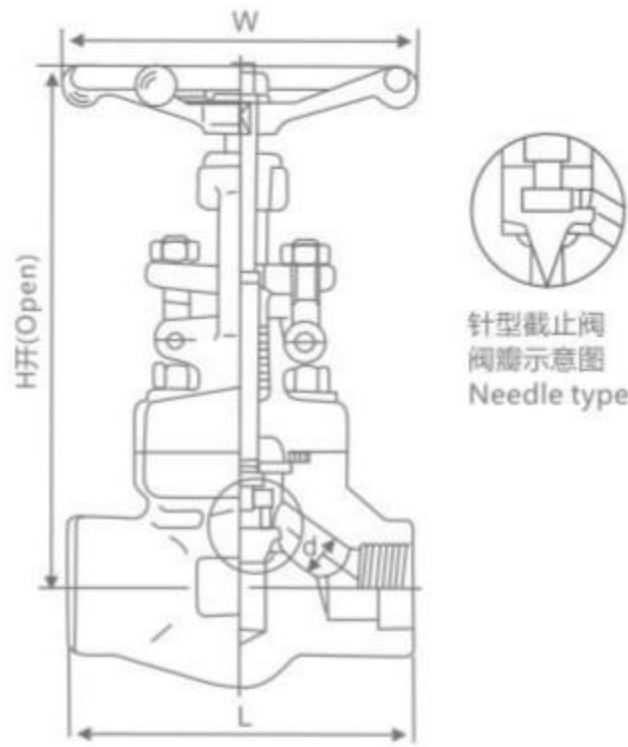

CL800

规格(NPS)Specification	R. P	1/2	3/4	1	1 1/4	1 1/2	2	2 1/2	3	
	F. P	1/4	3/8	1/2	3/4	1	1 1/4	1 1/2	2	2 1/2
结构长度(mm)Face to face	L	79	79	92	111	120	152	172	200	-
手轮直径(mm)Handwheel diameter	W	100	100	100	125	160	160	180	200	-
中心高度(开)(mm)Height	H	164	164	164	203	224	260	300	355	-
流道孔径(mm)Flow port dimension	d	7	9	13	17.5	23	30	35	46	-
重量(Kg)Weight		1.9	2.28	2.37	4.3	5.75	7.8	12.5	17.5	-

螺栓连接阀盖, 缩径和全径, 明杆支架 (OS&Y), 末端连接可按螺纹或承插焊, 设计按BS5352
Bolted bonnet, full port reducing port outside screw and yoke(OS&Y)
Threaded, butt-welded or socket welded ends; design to BS5352

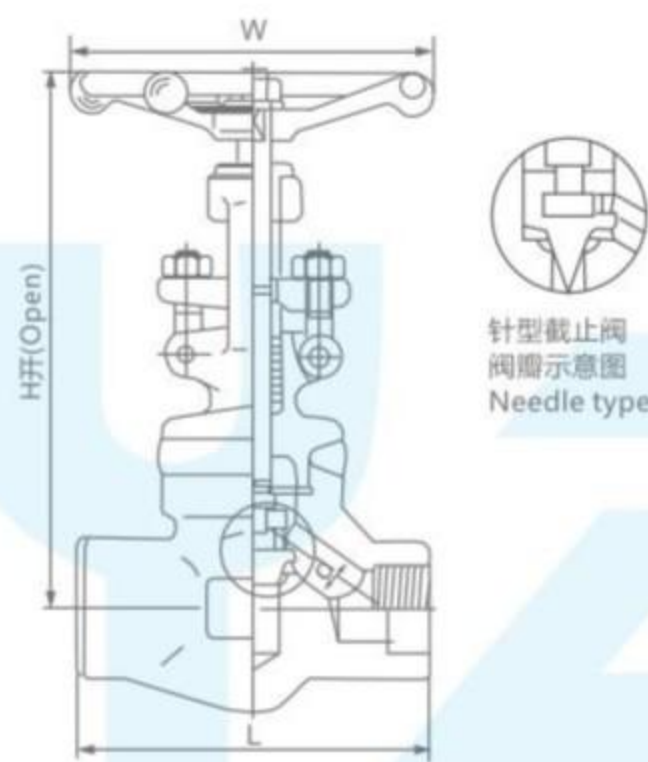

CL800

规格(NPS)Specification	R. P	1/2	3/4	1	1 1/4	1 1/2	2	2 1/2	3	
	F. P	1/4	3/8	1/2	3/4	1	1 1/4	1 1/2	2	2 1/2
结构长度(mm)Face to face	L	79	79	92	111	120	152	172	200	-
手轮直径(mm)Handwheel diameter	W	100	100	100	125	160	160	180	200	-
中心高度(开)(mm)Height	H	164	164	164	203	224	260	300	355	-
流道孔径(mm)Flow port dimension	d	7	9	13	17.5	23	30	35	46	-
重量(Kg)Weight		1.7	1.7	1.9	3.3	5.2	6.8	10.6	13.8	-

螺栓连接阀盖, 缩径和全径, 明杆支架 (OS&Y), 末端连接可按螺纹或承插焊, 设计按BS5352
Bolted bonnet, full port reducing port outside screw and yoke(OS&Y)
Threaded, butt-welded or socket welded ends; design to BS5352

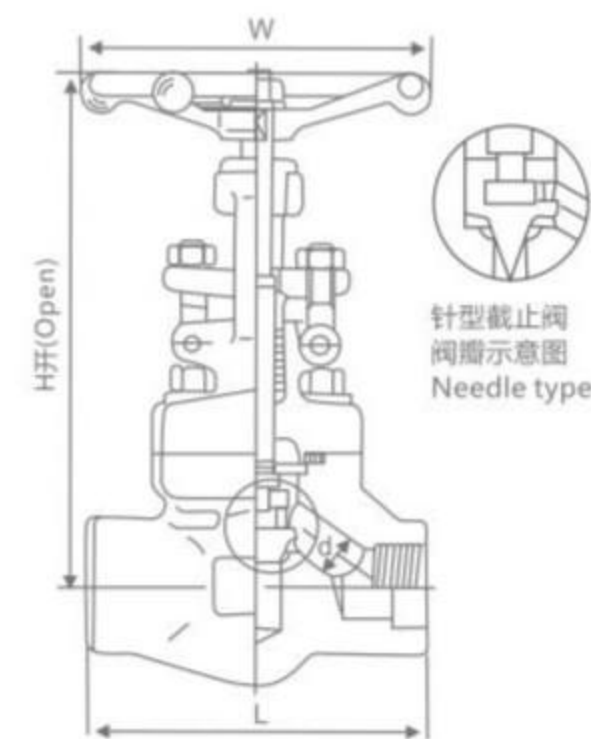

CL900-CL1500

规格(NPS)Specification	R. P	1/2	3/4	1	1 1/4	1 1/2	2	2 1/2	3
	F. P	1/4	3/8	1/2	3/4	1	1 1/4	1 1/2	2
结构长度(mm)Face to face	L	92	111	111	120	152	172	200	220
手轮直径(mm)Handwheel diameter	W	100	125	125	160	160	180	200	240
中心高度(开)(mm)Height	H	171	207	207	240	258	330	355	370
流道孔径(mm)Flow port dimension	d	7	12	15	20	28	32	40	45
重量(Kg)Weight		2.3	3.6	3.7	6.8	7.6	11.6	15	21.9

螺栓连接阀盖, 缩径和全径, 明杆支架 (OS&Y), 末端连接可按螺纹或承插焊, 设计按BS5352
Bolted bonnet, full port reducing port outside screw and yoke(OS&Y)
Threaded, butt-welded or socket welded ends; design to BS5352

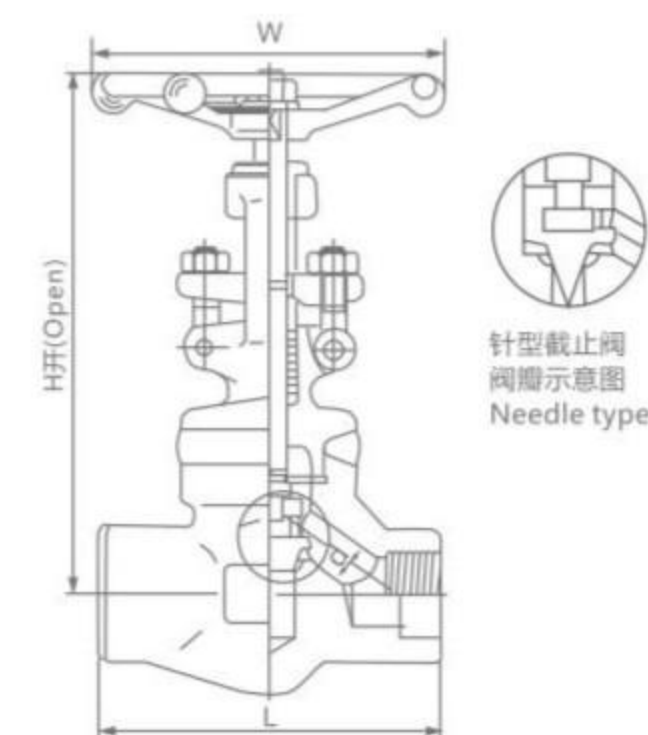

CL900-CL1500

规格(NPS)Specification	R. P	1/2	3/4	1	1 1/4	1 1/2	2	2 1/2	3
	F. P	1/4	3/8	1/2	3/4	1	1 1/4	1 1/2	2
结构长度(mm)Face to face	L	92	111	111	120	152	172	200	220
手轮直径(mm)Handwheel diameter	W	100	125	125	160	160	180	200	240
中心高度(开)(mm)Height	H	171	207	207	240	258	330	355	370
流道孔径(mm)Flow port dimension	d		12	15	20	28	32	40	45
重量(Kg)Weight		2.2	3.3	3.4	5.6	6.0	10.3	14.2	18.0

螺栓连接阀盖, 缩径和全径, 明杆支架 (OS&Y), 末端连接可按螺纹或承插焊, 设计按BS5352
Bolted bonnet, full port reducing port outside screw and yoke(OS&Y)
Threaded, butt-welded or socket welded ends; design to BS5352

INTERNAL THREAD AND SOCKET WELD STOP VALVE

内螺纹与承插焊截止阀

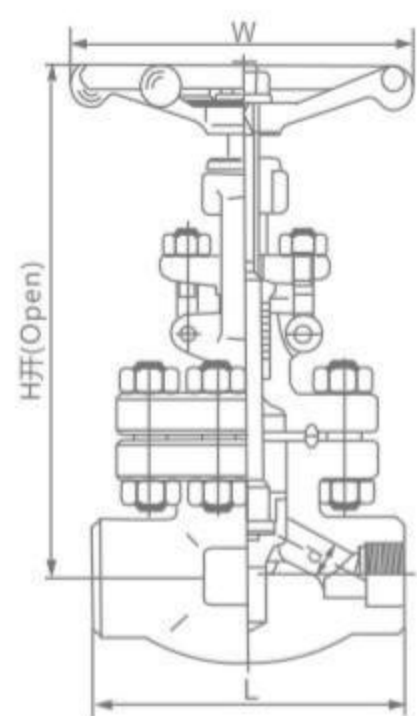

CL900-CL1500

规格(NPS) Specification	F.P	1/2	3/4	1	1 1/4	1 1/2	2	2 1/2
结构长度(mm)Face to face	L	110	110	150	150		210	235
手轮直径(mm)Handwheel diameter	W	110	110	130	180		210	250
中心高度(开)(mm)Height	H	227	227	300	307		400	448
流道孔径(mm)Flow port dimension	d	9	12	15	20		32	40
重量(Kg)Weight		5	5	10	11.5		22	37

螺栓连接阀盖(RJ), 全径, 明杆支架 (OS&Y), 末端连接为螺纹或承插焊, 设计按BS5352
Bolted bonnet, full port outside screw and yoke(OS&Y)
Threaded, butt-welded or socket welded ends; design to BS5352

CL900-CL1500

规格(NPS) Specification	F.P	1/2	3/4	1	1 1/4	1 1/2	2	2 1/2
结构长度(mm)Face to face	L	140	140	140	178	178	216	
手轮直径(mm)Handwheel diameter	W	200	200	200	280	280	300	
中心高度(开)(mm)Height	H	320	320	320	440	440	490	
流道孔径(mm)Flow port dimension	d	12	15	20	28	32	40	
重量(Kg)Weight		10.8	10.5	11.5	19.6	21.1	55.4	

螺栓连接阀盖(RJ), 全径, 明杆支架 (OS&Y), 末端连接为螺纹或承插焊, 设计按BS5352
Bolted bonnet, full port outside screw and yoke(OS&Y)
Threaded, butt-welded or socket welded ends; design to BS5352

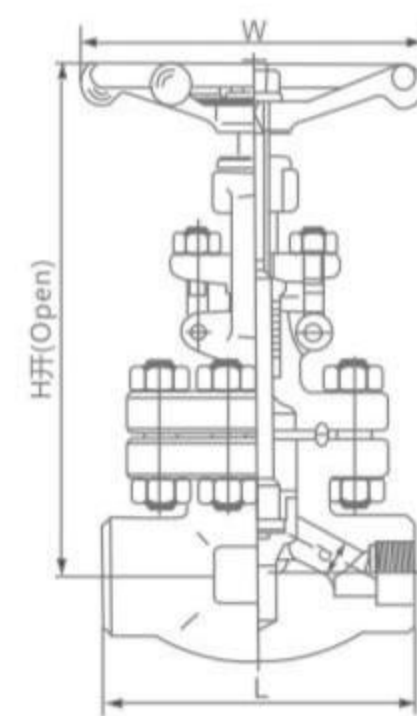
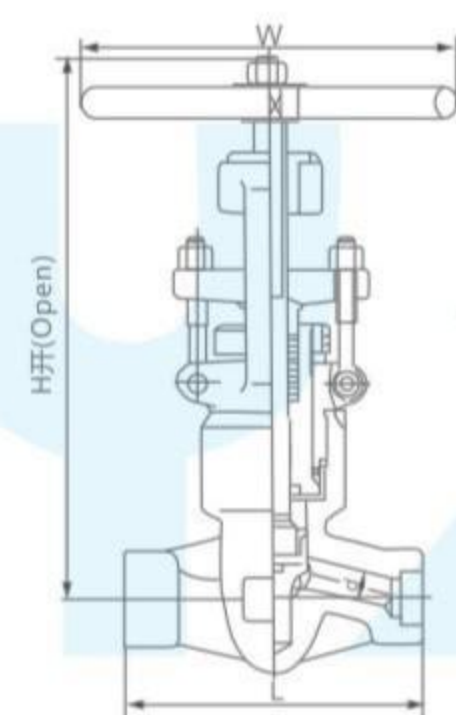

焊接阀盖示意图
Welded bonnet

CL2500

规格(NPS) Specification	F.P	1/2	3/4	1	1 1/4	1 1/2	2	2 1/2
结构长度(mm)Face to face	L	150	150	210		235	235	
手轮直径(mm)Handwheel diameter	W	130	130	250		300	300	
中心高度(开)(mm)Height	H	293	300	390		435	435	
流道孔径(mm)Flow port dimension	d	11	17	19		28	35	
重量(Kg)Weight		10	10.3	22.4		38	38	

螺栓连接阀盖(RJ), 全径, 明杆支架 (OS&Y), 末端连接为承插焊, 设计按ASME B16.34
Bolted bonnet, full port outside screw and yoke(OS&Y)
Socket welded ends; design conform to ASME B16.34

CL2500

规格(NPS) Specification	F.P	1/2	3/4	1	1 1/4	1 1/2	2	2 1/2
结构长度(mm)Face to face	L	186	186	186	232	232	279	
手轮直径(mm)Handwheel diameter	W	200	200	200	280	280	300	
中心高度(开)(mm)Height	H	375	378	380	490	490	540	
流道孔径(mm)Flow port dimension	d	11	14	19	25	28	35	
重量(Kg)Weight		10.8	11.6	12.3	26.0	28.4	60	

螺栓连接阀盖(RJ), 全径, 明杆支架 (OS&Y), 末端连接为承插焊, 设计按ASME B16.34
Bolted bonnet, full port outside screw and yoke(OS&Y)
Socket welded ends; design conform to ASME B16.34

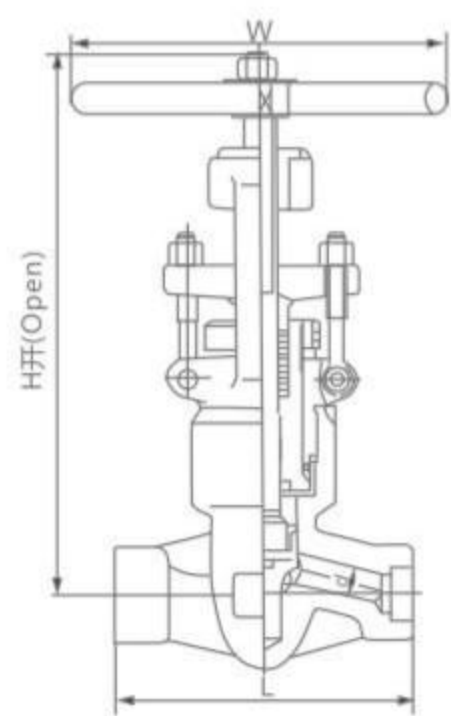

INTERNAL THREAD AND SOCKET WELD STOP VALVE

内螺纹与承插焊截止阀

CL800

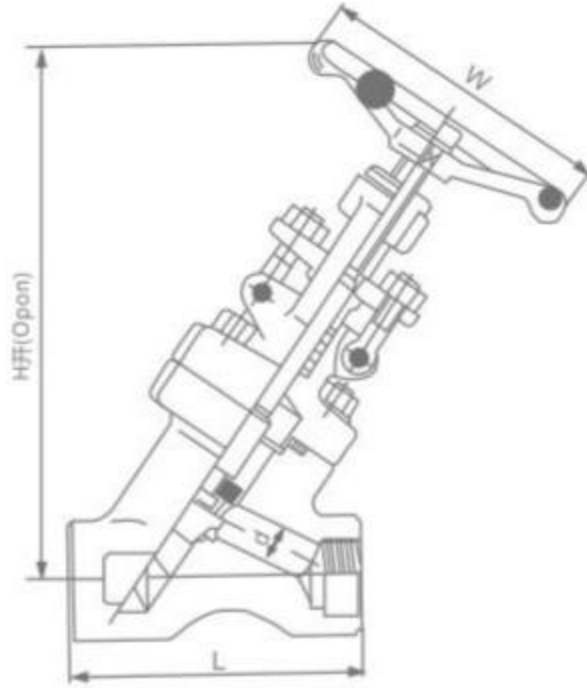

规格(NPS)Specification	R. P	1/2	3/4	1	1 1/4	1 1/2	2	2 1/2	3	
	F. P	1/4	3/8	1/2	3/4	1	1 1/4	1 1/2	2	2 1/2
结构长度(mm)Face to face	L	98	98	98	111	140	140	155	170	
手轮直径(mm)Handwheel diameter	W	100	100	100	125	160	160	180	200	
中心高度(开)(mm)Height	H	180	180	180	188	280	280	295	350	
流道孔径(mm)Flow port dimension	d	7	9	13	17.5	23	30	35	46	
重量(Kg)Weight		2.6	2.6	3.8	4.5	9.3	9.3	14	19.6	

螺栓连接阀盖, 缩径和全径, 明杆支架 (OS&Y), 末端连接可按螺纹或承插焊, 设计按BS5352
Bolted bonnet, full port reducing port outside screw and yoke(OS&Y)
Threaded, butt-welded or socket welded ends; design to BS5352

CL800

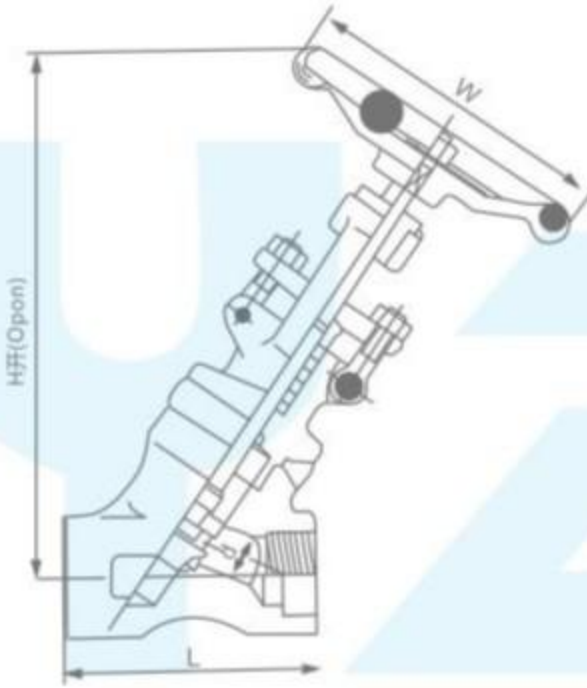

规格(NPS)Specification	R. P	1/2	3/4	1	1 1/4	1 1/2	2	2 1/2	3	
	F. P	1/4	3/8	1/2	3/4	1	1 1/4	1 1/2	2	2 1/2
结构长度(mm)Face to face	L	79	79	92	100	140	140	155	170	
手轮直径(mm)Handwheel diameter	W	100	100	100	125	160	160	180	200	
中心高度(开)(mm)Height	H	198	198	198	207	280	280	295	350	
流道孔径(mm)Flow port dimension	d	7	9	13	17.5	23	30	35	46	
重量(Kg)Weight		1.8	1.8	2.0	3.5	8.0	8.0	12	16	

螺栓连接阀盖, 缩径和全径, 明杆支架 (OS&Y), 末端连接可按螺纹或承插焊, 设计按BS5352
Bolted bonnet, full port reducing port outside screw and yoke(OS&Y)
Threaded, butt-welded or socket welded ends; design to BS5352

CL900-CL1500

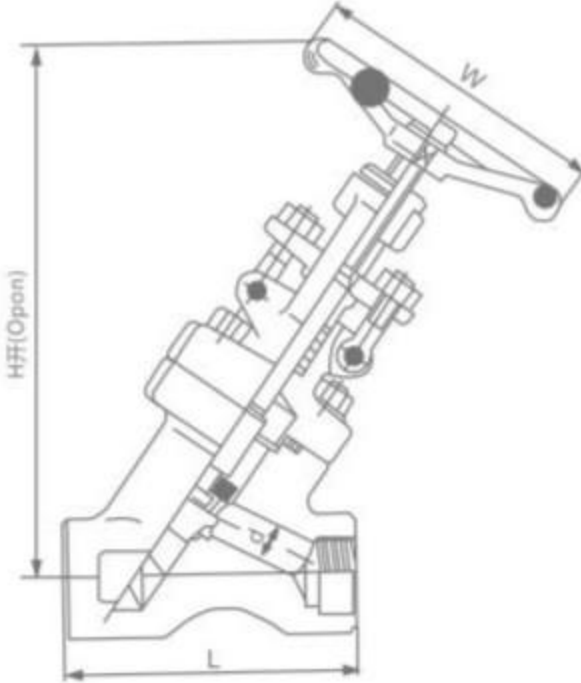

规格(NPS)Specification	F.P	3/8	1/2	3/4	1	1 1/4	1 1/2	2	2 1/2
结构长度(mm)Face to face	L	98	111	111	140	140	155	170	
手轮直径(mm)Handwheel diameter	W	100	125	125	160	160	180	200	
中心高度(开)(mm)Height	H	175	175	215	215	254	305	305	
流道孔径(mm)Flow port dimension	d	9	12	15	20	28	32	40	
重量(Kg)Weight		2.6	4.6	4.6	9.3	9.3	14	19.6	

螺栓连接阀盖, 缩径和全径, 明杆支架 (OS&Y), 末端连接可按螺纹或承插焊, 设计按BS5352
Bolted bonnet, full port reducing port outside screw and yoke(OS&Y)
Threaded, butt-welded or socket welded ends; design to BS5352

CL900-CL1500

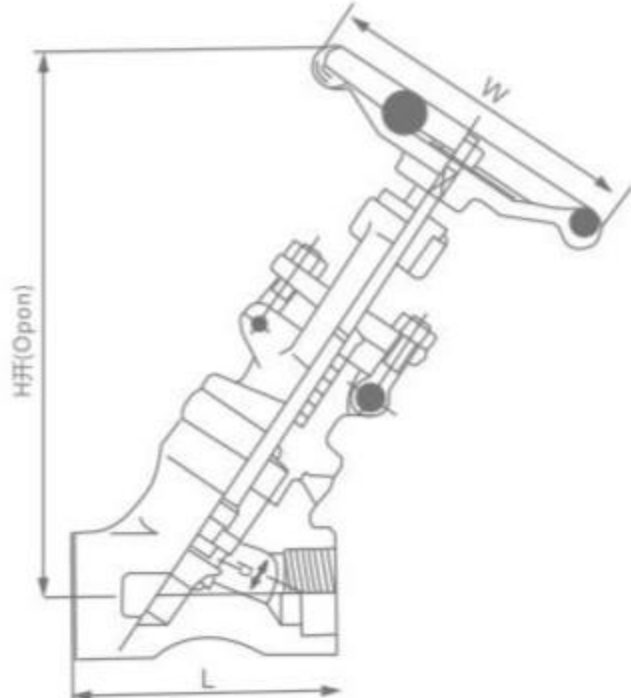

规格(NPS)Specification	F.P	3/8	1/2	3/4	1	1 1/4	1 1/2	2	2 1/2
结构长度(mm)Face to face	L	92	100	100	140	140	155	170	
手轮直径(mm)Handwheel diameter	W	100	125	125	160	160	180	200	
中心高度(开)(mm)Height	H	175	207	207	280	280	295	350	
流道孔径(mm)Flow port dimension	d	9	12	15	20	28	32	40	
重量(Kg)Weight		1.8	3.5	3.5	8.0	8.0	12	16	

螺栓连接阀盖, 缩径和全径, 明杆支架 (OS&Y), 末端连接可按螺纹或承插焊, 设计按BS5352
Bolted bonnet, full port reducing port outside screw and yoke(OS&Y)
Threaded, butt-welded or socket welded ends; design to BS5352

FLANGE AND BUTT-WELDED GLOBE VALVE

法兰与对焊截止阀

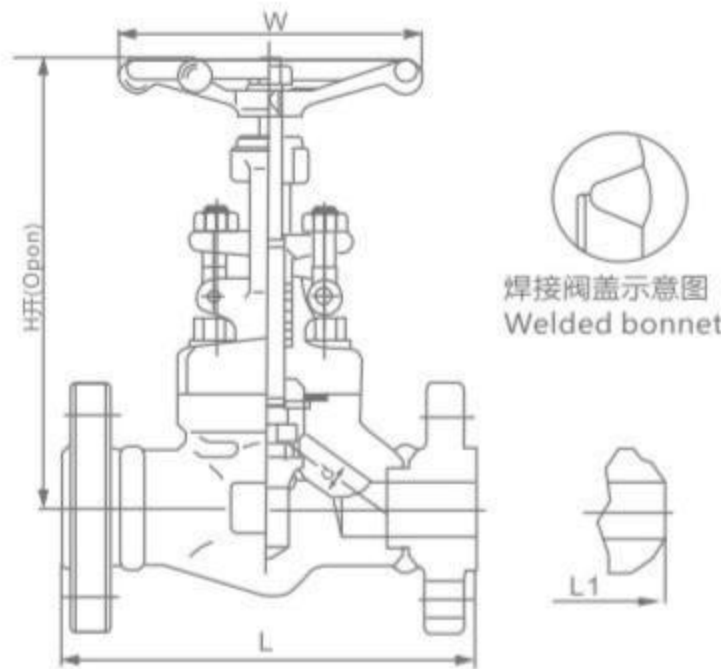

CL150-300-600

规格(NPS) Specification			1/4	3/8	1/2	3/4	1	1 1/4	1 1/2	2
结构长度(mm) Face to face	CL150	L(RF) L1(BW)	-	-	108	117	127	140	165	203
	CL300		-	-	152	178	203	216	229	267
	CL600		-	-	165	190	216	229	241	292
手轮直径(mm) Handwheel diameter	W	-	-	100	100	125	160	160	180	
中心高度(开) (mm)Height	CL150/CL300	H	-	-	180	184	217	224	260	300
	CL600		-	-	164	164	203	224	260	300
流道孔径(mm) Flow port dimension	d	-	-	9	13	17.5	23	30	35	
重量(Kg) Weight	CL150	RF	-	-	3.45	4.0	6.19	9.6	10.5	17
		BW	-	-	2.3	3.6	7.8	8.2	12.0	15.0
	CL300	RF	-	-	3.8	5.1	7.2	12	13.5	19.7
		BW	-	-	2.8	4.0	8.5	9.2	12.6	16.8
	CL600	RF	-	-	5.6	7.8	12.5	17	23.5	38.8
		BW	-	-	3.4	4.7	9.2	10.5	13.3	18.9

注：如需法兰和阀体一体式锻造的请与TIANBANG销售人员联系。

Flange integrity Forged Steel Valve Enquiry Please Contact Sales Department.

螺栓连接阀盖，全径，明杆支架（OS&Y），末端连接为焊接法兰或对焊连接，设计按 Bs5352

Welded bonnet, full port outside screw and yoke(OS&Y), Flange-welded or but-welded ends; design to BS5352

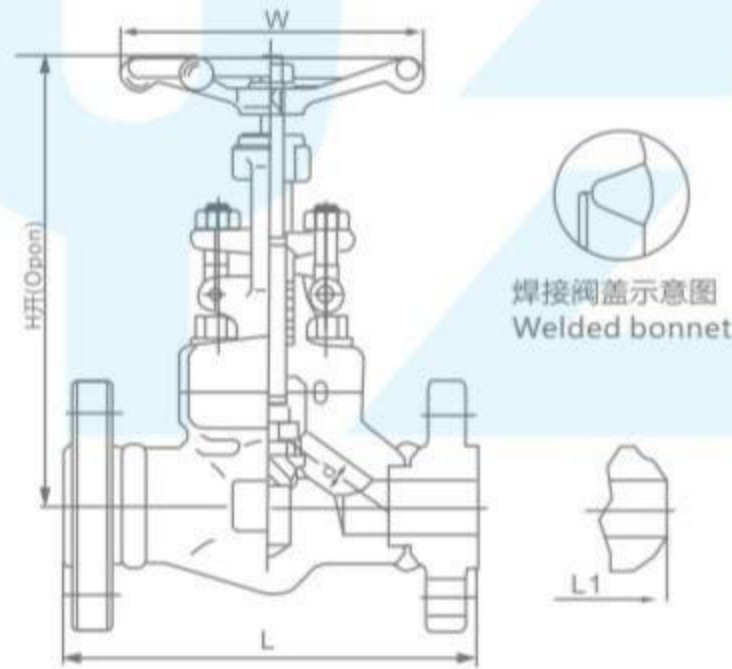

CL900-CL1500

规格(NPS) Specification		F. P	1/4	3/8	1/2	3/4	1	1 1/4	1 1/2	2
结构长度(mm) Face to face	L(RF)L1(BW)	-	-	216	229	254	279	305	368	
	L(RTJ)	-	-	216	229	254	279	305	371	
手轮直径(mm) Handwheel diameter	W	-	-	125	125	160	160	180	200	
中心高度(开)(mm) Height	H	-	-	207	207	230	160	300	355	
流道孔径(mm) Flow port dimension	d	-	-	12	15	20	28	32	40	
重量(Kg) Weight		-	-	11	13.2	17.4	19	24.5	31	

注：如需法兰和阀体一体式锻造的请与TIANBANG销售人员联系。

Flange integrity Forged Steel Valve Enquiry Please Contact Sales Department.

螺栓连接阀盖，全径，明杆支架（OS&Y），末端连接为焊接法兰或对焊连接，设计按 Bs5352

Welded bonnet, full port outside screw and yoke(OS&Y), Flange-welded or but-welded ends; design to BS5352

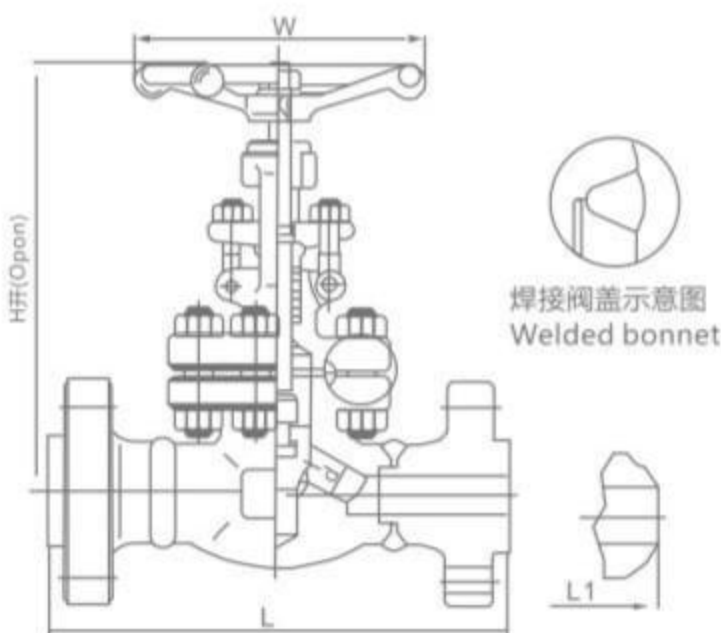

CL2500

规格(NPS) Specification		F. P	1/4	3/8	1/2	3/4	1	1 1/4	1 1/2	2
结构长度(mm) Face to face	L(RF)L1(BW)	-	-	264	273	308	-	384	451	
	L(RTJ)	-	-	264	273	308	-	387	454	
手轮直径(mm) Handwheel diameter	W	-	-	125	160	200	-	250	240	
中心高度(开)(mm) Height	H	-	-	207	240	258	-	355	300	
流道孔径(mm) Flow port dimension	d	-	-	11	14	19	-	28	35	
重量(Kg) Weight		-	-	19.5	21.5	42	-	65	95	

螺栓连接阀盖（RJ），全径，明杆支架（OS&Y），末端连接为焊接法兰或对焊连接，设计按ASME B16.34

Welded bonnet, full port outside screw and yoke(OS&Y), Flange-welded or but-welded ends; design to ASME B16.34

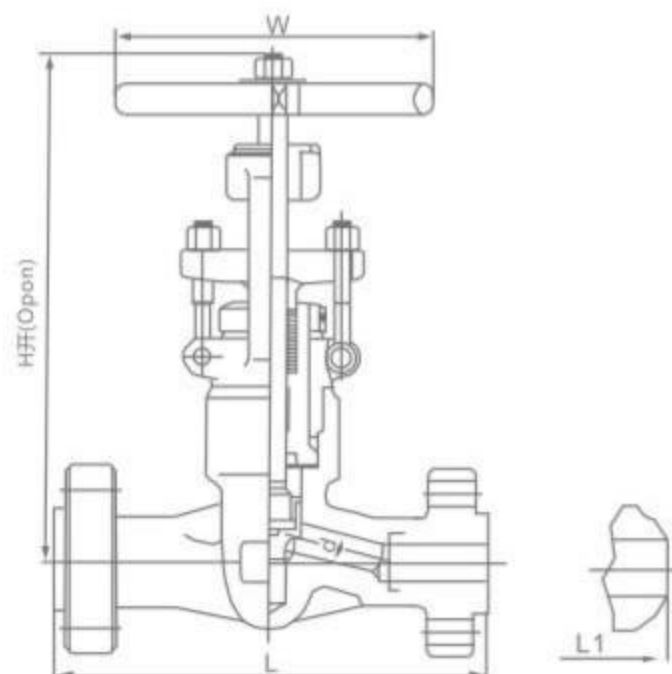

CL2500

规格(NPS) Specification		F. P	1/4	3/8	1/2	3/4	1	1 1/4	1 1/2	2
结构长度(mm) Face to face	L(RF)L1(BW)	-	-	264	273	308	394	384	451	
	L(RTJ)	-	-	264	273	308	394	387	454	
手轮直径(mm) Handwheel diameter	W	-	-	200	200	280	280	280	300	
中心高度(开)(mm) Height	H	-	-	320	320	320	440	440	490	
流道孔径(mm) Flow port dimension	d	-	-	11	14	19	25	28	35	
重量(Kg) Weight		-	-	21.5	24.7	30.4	48.1	58.1	130	

压力自紧式密封闸阀，全径，明杆支架（OS&Y），末端连接为焊接法兰或对焊连接，设计按ASME B16.34

Pressure seal gate valves, full port outside screw and yoke(OS&Y)

Flange-welded or but-welded ends; design to ASME B16.34

FEMALE THREAD AND SOCKET WELDED CHECK VALVE

内螺纹与承插焊止回阀

CL800

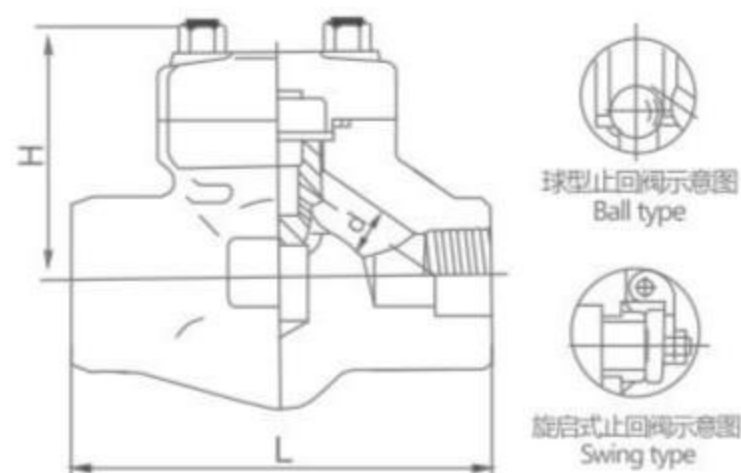

规格(NPS) Specification	F.P		3/8	3/4	1	1 1/4	1 1/2	2	2	
	R.P		1/4	3/8	1/2	3/4	1	1 1/2	200	
结构长度(mm) Face to face	L	升降式Lift	79	79	92	111	120	152	172	178
		旋启式Swing	79	79	92	111	120	120	140	132
中心高度(开)(mm)Height	H	升降式Lift	61	61	61	78	84	84	118	133
		旋启式Swing	61	61	61	78	84	84	120	46
流道孔径(mm) Flow port dimension	d	升降式Lift	7	9	13	17.5	23	30	35	45
		旋启式Swing	8	10.5	13.5	18	24	29	36.5	12.5
重量(Kg)Weight		升降式Lift	1.2	1.5	1.7	3.3	4.2	4.2	10.5	10.9
		旋启式Swing	1.4	1.5	1.7	3.3	4.2	4.2	8.5	

螺栓连接阀盖, 缩径和全径, 末端连接为螺纹或承插焊或对焊, 设计按BS5352
Bolted bonnet, full port & reducing port, Threaded, but-welded or socket welded ends; design to BS5352

CL800

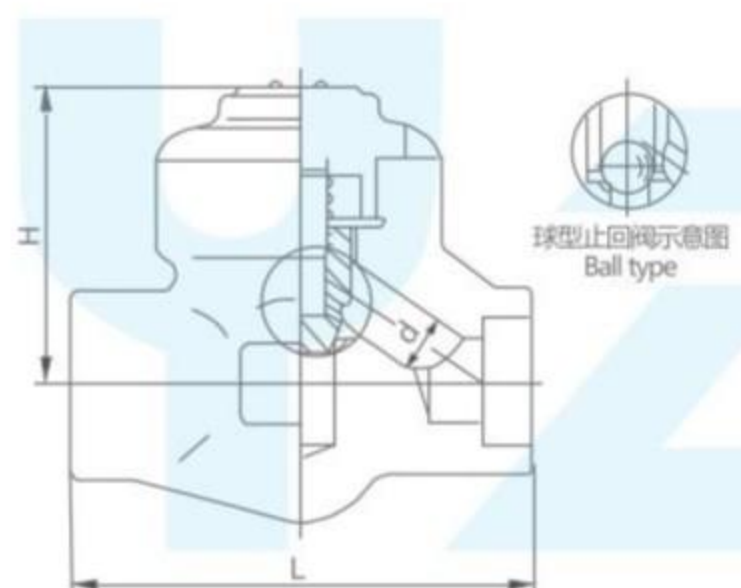

规格(NPS) Specification	F.P	-	1/2	3/4	1	1 1/4	1 1/2	2	2 1/2
	R.P	1/4	3/8	1/2	3/4	1	1 1/4	1 1/2	2
结构长度(mm) Face to face	L	79	79	92	111	120	152	172	200
中心高度(开)(mm)Height	H	61	61	61	78	84	103	118	132
流道孔径(mm) Flow port dimension	d	7	9	13	17.5	23	30	35	46
重量(Kg)Weight		1.2	1.3	1.5	3.0	3.9	6.0	10	12

螺栓连接阀盖, 缩径和全径, 末端连接为螺纹或承插焊或对焊, 设计按BS5352
Bolted bonnet, full port & reducing port, Threaded, but-welded or socket welded ends; design to BS5352

CL900-CL1500

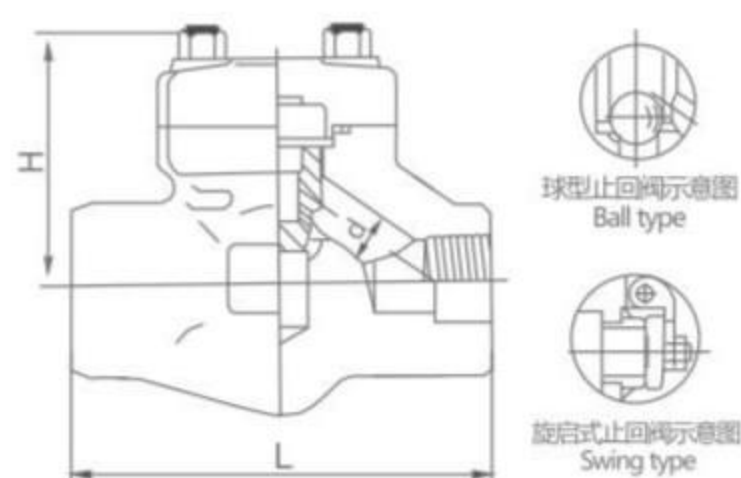

规格(NPS) Specification	F.P		3/8	3/4	1	1 1/4	1 1/2	2	2
	R.P		1/4	3/8	1/2	3/4	1	1 1/2	200
结构长度(mm) Face to face	L	升降式Lift	92	111	111	120	152	172	200
		旋启式Swing	92	111	111	120	120	140	178
中心高度(开)(mm)Height	H	升降式Lift	61	78	78	84	103	118	132
		旋启式Swing	61	78	78	84	101	120	133
流道孔径(mm) Flow port dimension	d	升降式Lift	7	12	15	20	28	32	40
		旋启式Swing	8	10.5	13.5	18	24	29	45
重量(Kg)Weight		升降式Lift	1.5	3.4	3.3	4.2	6.3	10.5	12.5
		旋启式Swing	1.5	3.3	3.4	4.2	5.0	8.5	10.9

螺栓阀盖, 缩径和全径, 末端连接为螺纹或承插焊, 设计按BS5352
Bolted bonnet, full port & reducing port, Threaded, but-welded or socket welded ends; design to BS5352

CL900-CL1500

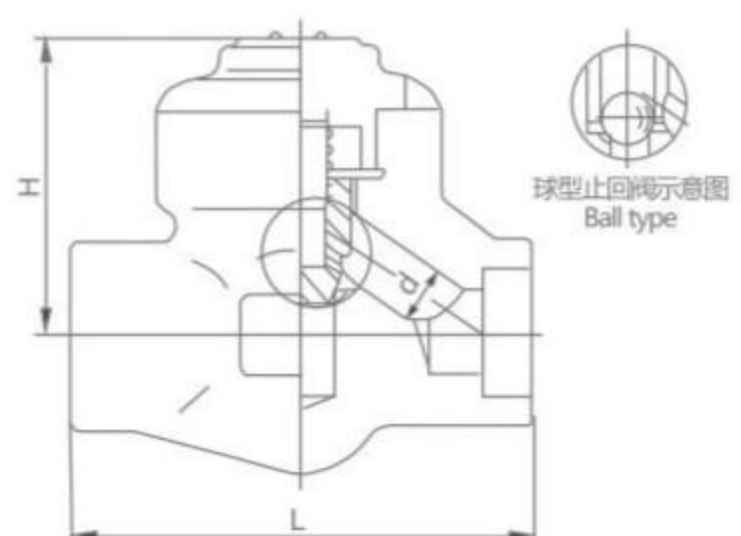

规格(NPS) Specification	F.P	-	1/2	3/4	1	1 1/4	1 1/2	2	2 1/2
	R.P	1/4	3/8	1/2	3/4	1	1 1/4	1 1/2	2
结构长度(mm) Face to face	L	92	111	111	120	152	172	200	
中心高度(开)(mm)Height	H	61	78	78	84	103	118	132	
流道孔径(mm) Flow port dimension	d	7	12	15	20	28	32	40	
重量(Kg)Weight		1.3	3.1	3.1	3.9	5.8	10.0	11.5	

螺栓阀盖, 缩径和全径, 末端连接为螺纹或承插焊, 设计按BS5352
Bolted bonnet, full port & reducing port, Threaded, but-welded or socket welded ends; design to BS5352

FLANGE AND BUTT-WELDED CHECK VALVES

法兰与对焊止回阀

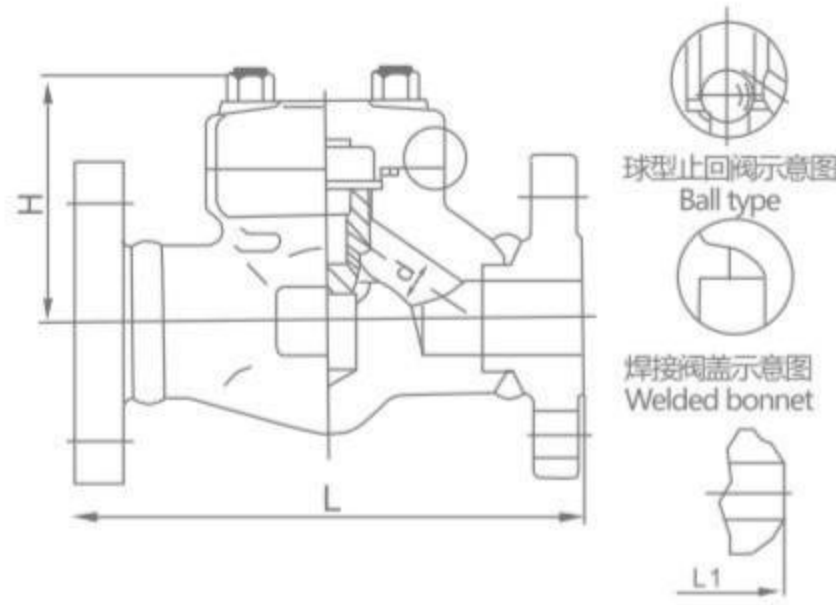

CL150-300-600

规格(NPS) Specification		R.P	1/4	3/8	1/2	3/4	1	1 1/4	1 1/2	2
结构长度(mm) Face to face	CL150	L(RF) L1(BW)	-	-	108	118	127	140	165	203
	CL300		-	-	153	178	203	216	229	267
	CL600		-	-	165	191	216	229	241	292
中心高度(开) (mm)Height	CL150	H	-	-	77	81	93	95	103	118
	CL300/CL600		-	-	61	78	84	101	120	133
流道孔径(mm)Flow port dimension		d	-	-	10	13	17.5	23	30	35
重量(Kg) Weight	CL150	RF	-	-	3.6	4.6	8.5	9.2	12.5	14.8
		BW	-	-	3.0	3.6	7.6	8.5	11.3	13.6
	CL300	RF	-	-	3.7	4.8	8.8	9.6	13.7	17.8
		BW	-	-	3.2	4.3	8.0	8.6	12.7	16.2
	CL600	RF	-	-	4.0	5.8	9.5	10.4	15.6	24.5
		BW	-	-	3.4	5.1	8.8	9.2	14.8	22.5

螺栓阀盖, 缩径, 末端连接为法兰或对焊, 设计按 BS5352

Bolted bonnet reducing port, Flange-welded or but-welded ends; design to BS5352

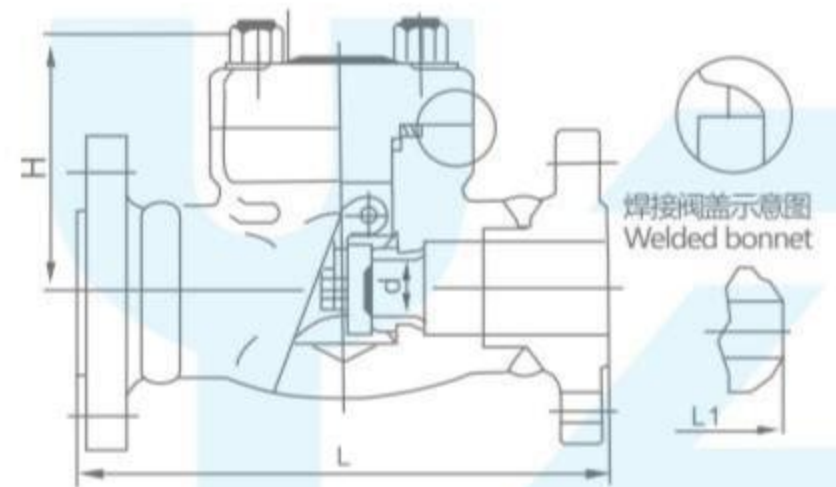

CL150-300-600

规格(NPS) Specification		R.P	1/4	3/8	1/2	3/4	1	1 1/4	1 1/2	2
结构长度(mm) Face to face	CL150	L(RF) L1(BW)	-	-	108	118	127	140	165	203
	CL300		-	-	153	178	203	216	229	267
	CL600		-	-	165	191	216	229	241	292
中心高度(开) (mm)Height	CL150	H	-	-	77	81	93	95	103	118
	CL300/CL600		-	-	61	78	84	101	120	133
流道孔径(mm)Flow port dimension		d	-	-	10.5	13.5	18	24	29	36.5
重量(Kg) Weight	CL150	RF	-	-	3.6	4.6	8.5	9.2	12.5	14.8
		BW	-	-	3.0	3.6	7.6	8.5	11.3	13.6
	CL300	RF	-	-	3.7	4.8	8.8	9.6	13.7	17.8
		BW	-	-	3.2	4.3	8.0	8.6	12.7	16.2
	CL600	RF	-	-	4.0	5.8	9.5	10.4	15.6	24.5
		BW	-	-	3.4	5.1	8.8	9.2	14.8	22.5

螺栓阀盖, 缩径, 末端连接为法兰或对焊, 设计按 BS5352

Bolted bonnet reducing port, Flange-welded or but-welded ends; design to BS5352

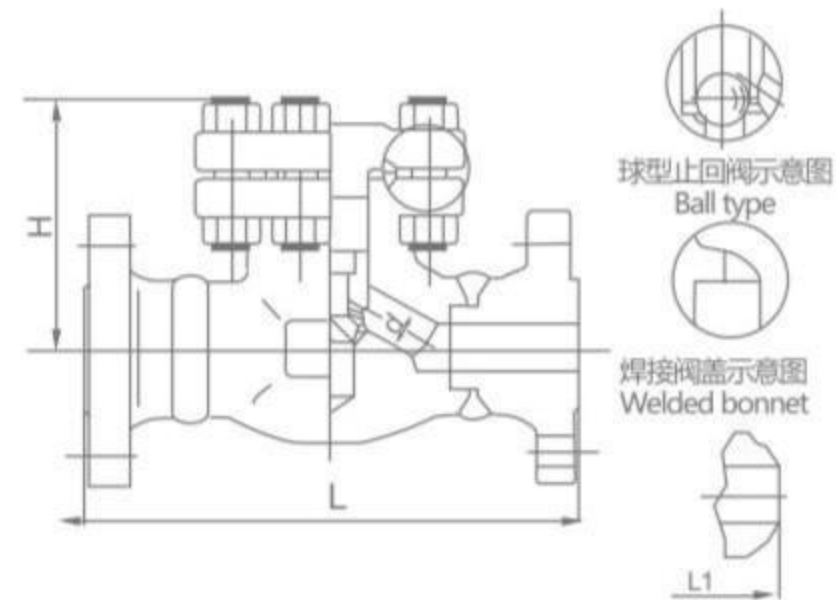

CL150-300-600

规格(NPS) Specification		R.P	1/4	3/8	1/2	3/4	1	1 1/4	1 1/2	2
结构长度(mm) Face to face	CL150	L(RF) L1(BW)	-	-	108	118	127	140	165	203
	CL300		-	-	153	178	203	216	229	267
	CL600		-	-	165	191	216	229	241	292
中心高度(开) (mm)Height	CL150	H	-	-	77	81	93	95	103	118
	CL300/CL600		-	-	61	78	84	101	120	133
流道孔径(mm)Flow port dimension		d	-	-	10	13	17.5	23	30	35
重量(Kg) Weight	CL150	RF	-	-	3.2	3.5	4.6	5.2	7.0	16
		BW	-	-	2.8	3.0	4.0	4.6	6.3	15
	CL300	RF	-	-	4.6	6.1	9.1	12	16	21
		BW	-	-	4.1	5.7	8.4	11.2	14.5	19.5
	CL600	RF	-	-	4.8	6.3	9.3	13	16.5	22
		BW	-	-	4.4	5.9	8.7	12.1	15.8	20.8

螺栓阀盖, 缩径, 末端连接为法兰或对焊, 设计按 BS5352

Bolted bonnet reducing port, Flange-welded or but-welded ends; design to BS5352

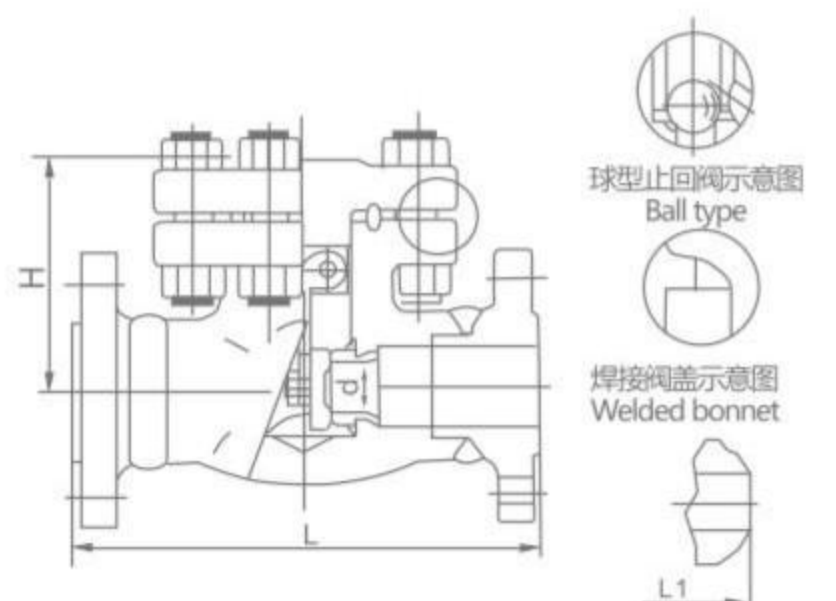

CL150-300-600

规格(NPS) Specification		R.P	1/4	3/8	1/2	3/4	1	1 1/4	1 1/2	2
结构长度(mm) Face to face	CL150	L(RF) L1(BW)	-	-	108	118	127	140	165	203
	CL300		-	-	153	178	203	216	229	267
	CL600		-	-	165	191	216	229	241	292
中心高度(开) (mm)Height	CL150	H	-	-	77	81	93	95	103	118
	CL300/CL600		-	-	61	78	84	101	120	133
流道孔径(mm)Flow port dimension		d	-	-	10.5	13.5	18	24	29	36.5
重量(Kg) Weight	CL150	RF	-	-	3.6	4.6	8.5	9.2	12.5	14.8
		BW	-	-	3.0	3.6	7.6	8.5	11.3	13.6
	CL300	RF	-	-	3.7	4.8	8.8	9.6	13.7	17.8
		BW	-	-	3.2	4.3	8.0	8.6	12.7	16.2
	CL600	RF	-	-	4.0	5.8	9.5	10.4	15.6	24.5
		BW	-	-	3.4	5.1	8.8	9.2	14.8	22.5

螺栓阀盖, 缩径, 末端连接为法兰或对焊, 设计按 BS5352

Bolted bonnet reducing port, Flange-welded or but-welded ends; design to BS5352